

M8 oder 5/16 UNF
 12x30° für Carbon Kupplung
 6x60° für metallische Kupplung

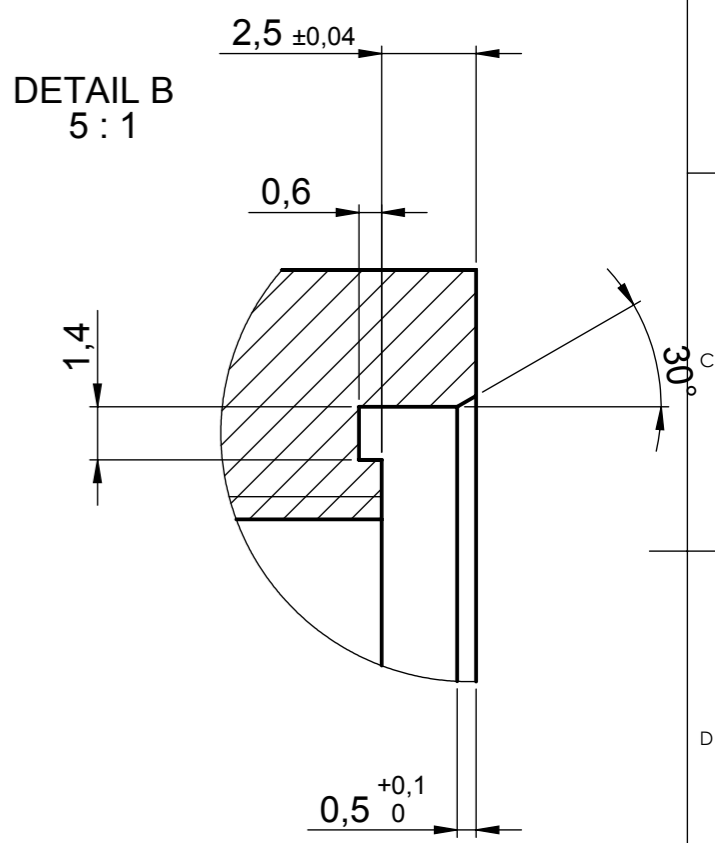
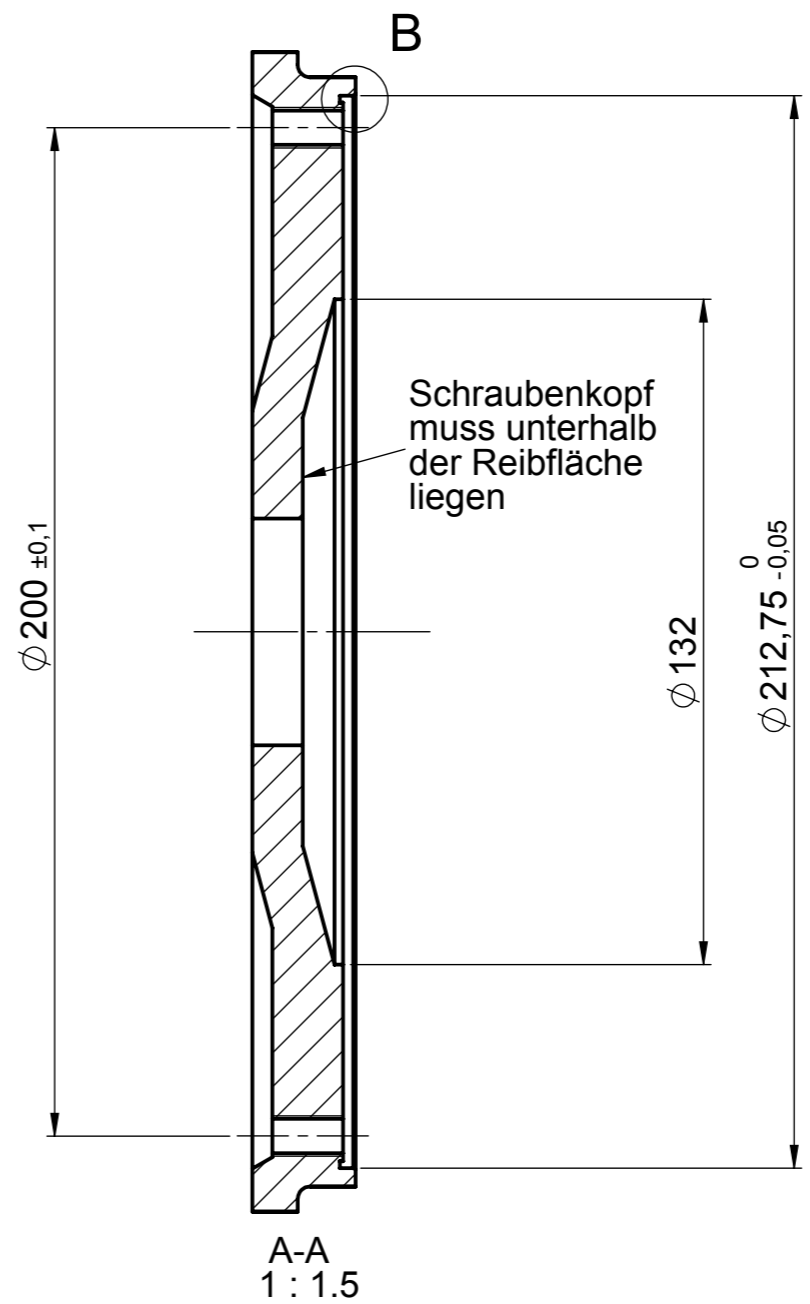

UNLESS OTHERWISE SPECIFIED: DIMENSIONS ARE IN MILLIMETERS SURFACE FINISH: TOLERANCES: LINEAR: ANGULAR:		Oberfläche:	MASSTAB:
NAME	DATUM	RTRAC GmbH 97490 Poppenhausen T: 0 97 25 50 75 F: 0 97 25 62 93 email: rtrac@t-online.de	Benennung: Bohrbild Schwungscheibe Kupplung ϕ 184 mm; aussen zentriert
gez: R. Endres	23.11.2004		
gepr:		MATERIAL:	Zeichnungsnr: A3
geönd:			
geönd:		GEWICHT:	